



混凝土喷浆车

TRUCK-MOUNTED CONCRETE SPRAYING MACHINE



Web: machmall.com

Tel: +86-516 8773 9797

E: machmall@xcmg.com

德国技术

GERMAN TECHNOLOGY

专业、极致，源自德国施维英的顶级技术

Specialty and acme originates from the top-level technology of SCHWING Germany

中国制造

MADE IN CHINA

落地德国制造高标准，实现产品的高可靠、超耐用

By implementing the high standard of German-made realizes highly reliable and durable products.

卓越品质

EXCELLENT QUALITY

用心设计，细节彰显尊重，品质赢得未来

Carefully designed, details demonstrates respect and quality wins the future.

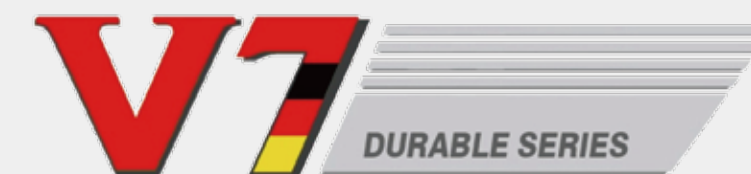

技术全面升级

COMPREHENSIVELY UPGRADED TECHNOLOGY

V7系列混凝土喷浆车

XCMG V7 SERIES TRUCK-MOUNTED CONCRETE SPRAYING MACHINE



超长的臂架结构技术

Super-long boom structure technology

更精准的臂架操控技术

More accurate boom control technology

更实用的双动力技术

More practical double-power technology

更高效的裙阀泵送系统

More efficient rock valve pumping system

更稳定的换向缓冲技术

Steadier reversing buffering technology

更可靠的全液压换向技术

More reliable fully-hydraulic reversing technology

超低压损的液压系统

Ultra-low pressure loss hydraulic system technology

DURABLE

ADVANCED



喷射范围更广 WIDER SPRAYING RANGE

- 最大喷射高度18m，前方最远喷射距离14.8m，最大喷射宽度29.6m。喷射范围更广。

- The max. spraying height is 18m, the farthest front spraying distance 14.8m, the max. spraying width 29.6m, so the spraying range is wider.



更灵活 MORE FLEXIBLE

- 创新设计的末端摆动臂架，配三自由度喷射机构，喷浆作业更加灵活，无死角。
- Innovative swing boom at end is matched with a spraying mechanism of three DOF to realize more flexible spraying operation, without dead angle



更安全 SAFER

- 基于高可靠、等强度理念设计，臂架全工况仿真计算与测试，严格执行德国施维英焊接标准，保障臂架高安全性。

- Based on the design philosophy of high reliability and equivalent strength, simulative calculation and testing of boom full-work-condition strictly implement SCHWING Germany's welding standard and ensures the high safety of boom.

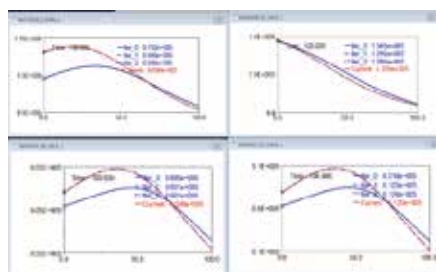

NO.1
SUPER-LONG BOOM
STRUCTURE TECHNOLOGY
超长的臂架结构技术

NO.2

MORE ACCURATE BOOM CONTROL TECHNOLOGY

精准的臂架操控技术

- 臂架微动控制技术和主动减震技术，臂架回转、变幅、伸缩及喷射等动作运行更加平稳，回转振幅减少60%，变幅振幅减少80%，定位更精准。
- With boom inching control technology and initiative shock absorption technology, such motions as boom slewing, elevating, telescoping and spraying are steadier, with slewing amplitude reduced by 60% , elevating amplitude reduced by 80% and positioning more accurate.

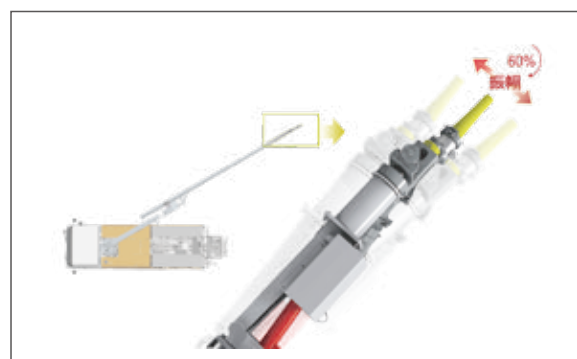
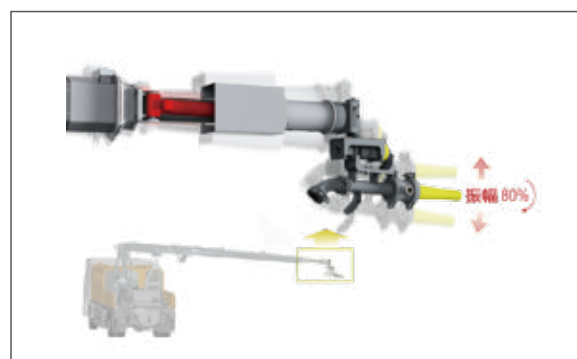

NO.3

MORE PRACTICAL DOUBLE-POWER TECHNOLOGY

更实用的双动力技术

- 除电机主动力外，底盘动力可实现无电状态下的臂架和支腿伸缩、速凝剂桶内速凝剂加注；泵送系统与高压水泵同时工作，确保整机清洗更加方便、高效。
- Besides the main power by motor, chassis power can realize boom and stabilizer telescoping without access to electricity and condensing agent feeding into IBC-tank; the simultaneous operation of pumping system and high-pressure water pump ensures more convenient and efficient cleaning of overall machine.

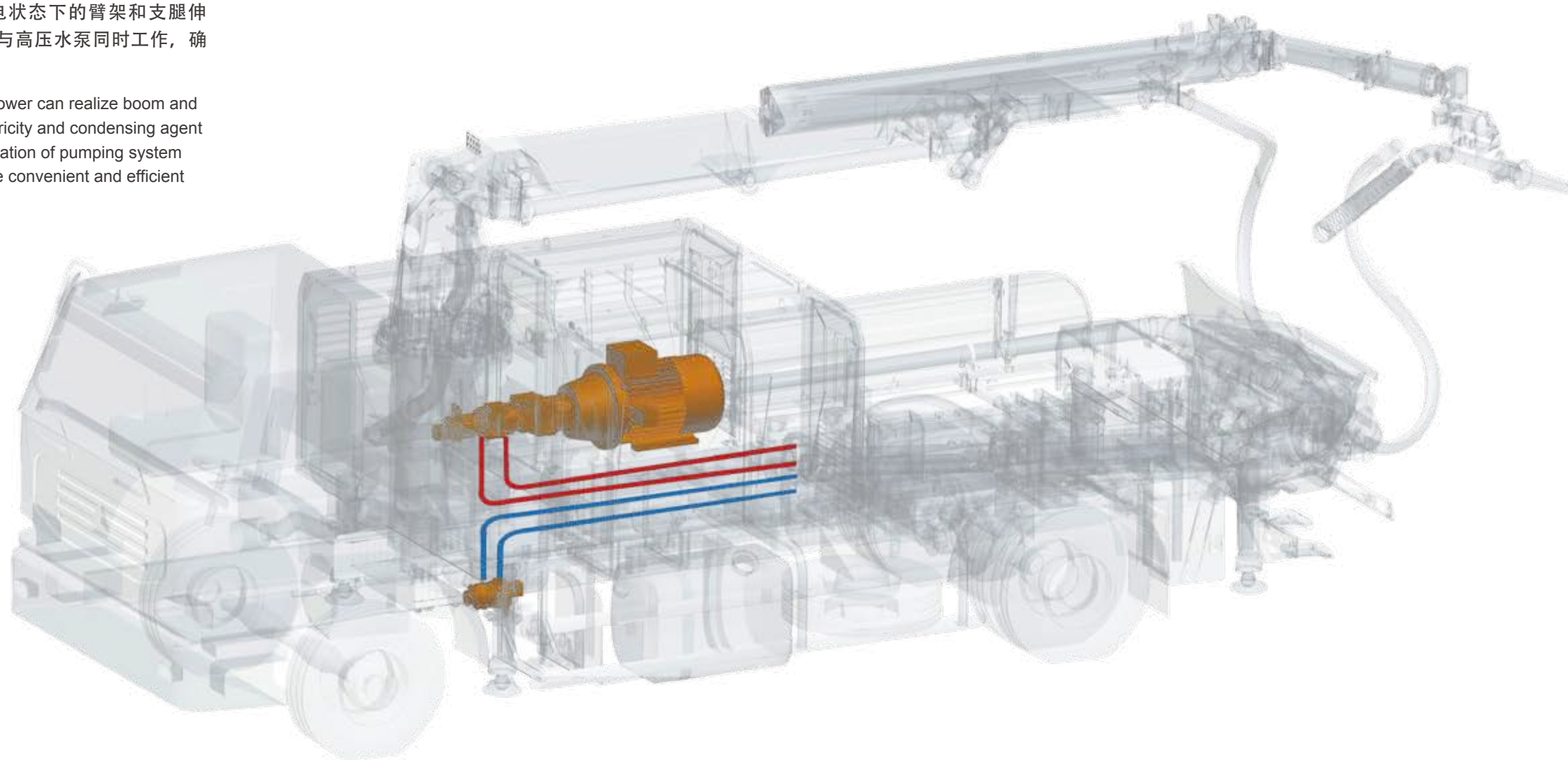

NO.4

MORE EFFICIENT ROCK VALVE PUMPING TECHNOLOGY

更高效的裙阀泵送系统

国际专利的裙阀技术

INTERNATIONALLY
PATENTED ROCK
VALVE TECHNOLOGY



- 基于激光引导的同轴装配，活塞头运行轨迹更精确，阻力更小，效率更高。
- Based on laser guide, coaxial assembly makes piston head's moving track more precise, with smaller resistance and higher efficiency.

易泵送;
Easy pumping;

轴端寿命更长;
Longer service life of shaft-end;

流道更平缓, 阻力更小, 油耗更低;
Gentler passageway, smaller resistance and lower oil consumption;

搅拌更充分, 吸收效率更高;
More uniform agitation and higher absorption efficiency;

单边磨损, 使用寿命更长;
One-side wear prolongs service life;

敞口式结构, 易于修复, 使用成本更低。
Open-mouth structure is easy for repair, lowering use cost.



NO.5

STEADIER REVERSING BUFFERING TECHNOLOGY

更稳定的换向缓冲技术

- 响应更快的阀控缓冲技术取代传统主泵减排技术;
- The valve control buffering technology with faster response replaces traditional pump emission reduction technology;
- 缓冲过程更稳定、更可靠、冲击更小;
- The buffering process is steadier and more reliable, with smaller impact;
- 换向时间缩短到0.1S以内，效率提升6%以上。
- The reversing time is shortened to be less than 0.1s and the efficiency is improved by more than 6%.

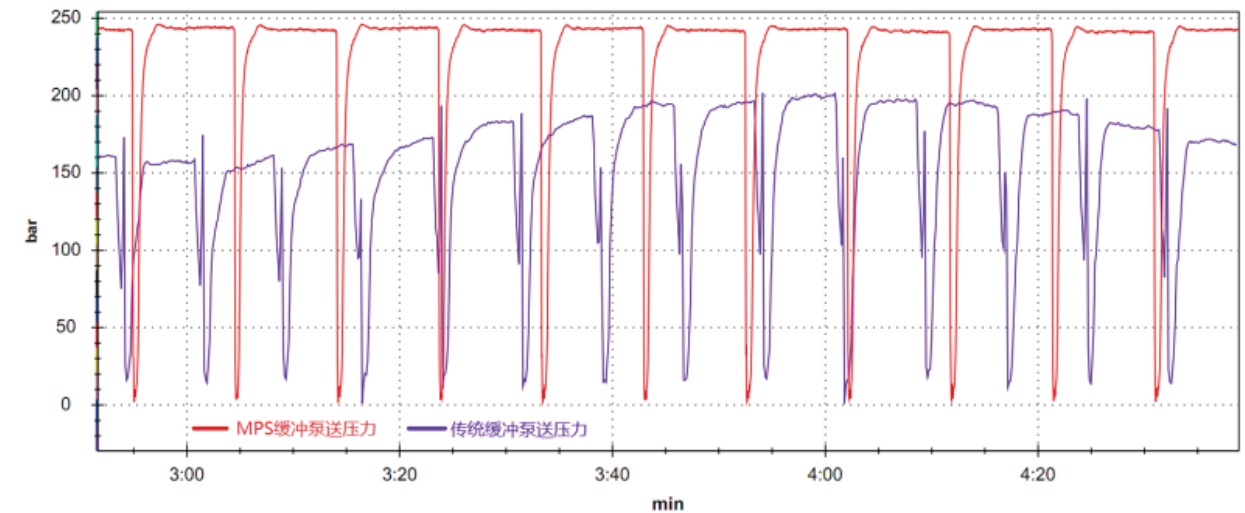

NO.6

MORE RELIABLE FULLY-HYDRAULIC REVERSING TECHNOLOGY

更可靠的全液压换向技术

- 德国施维英液压技术精髓，真正实现全液压换向，换向过程实现全液压闭环自适应控制，无需任何电气元件参与，更高效、更稳定、零污染。
- SCHWING Germany's hydraulic technology quintessence truly realizes fully-hydraulic reversing, in which self-adaption control in fully-hydraulic closed-loop is realized, with no need for any electrical components, more effective, steadier and zero-pollution.

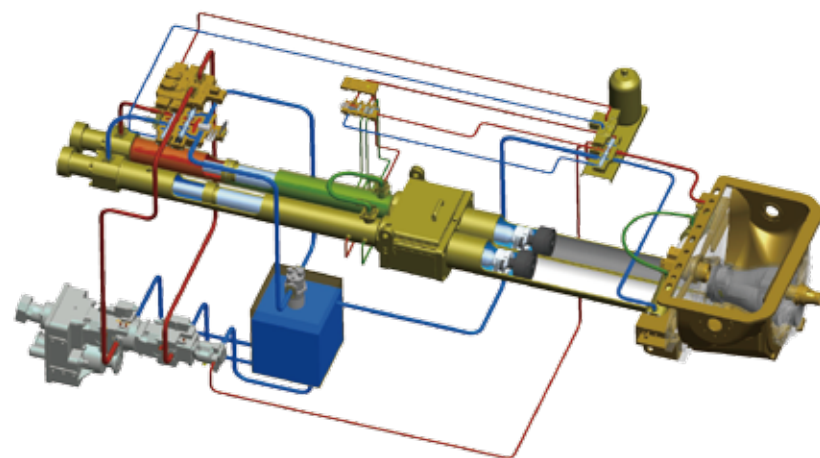

NO.7

ULTRA-LOW PRESSURE LOSS HYDRAULIC SYSTEM TECHNOLOGY

超低压损的液压系统

- 超低压损液压系统配合高效裙阀泵送系统，作业能耗更低，系统发热量小，整机能效更高。
- Ultra-low pressure loss hydraulic system, coordinated with efficient rock valve pumping system realizes lower energy consumption and heat emission in operation, improving the energy efficiency of overall machine.

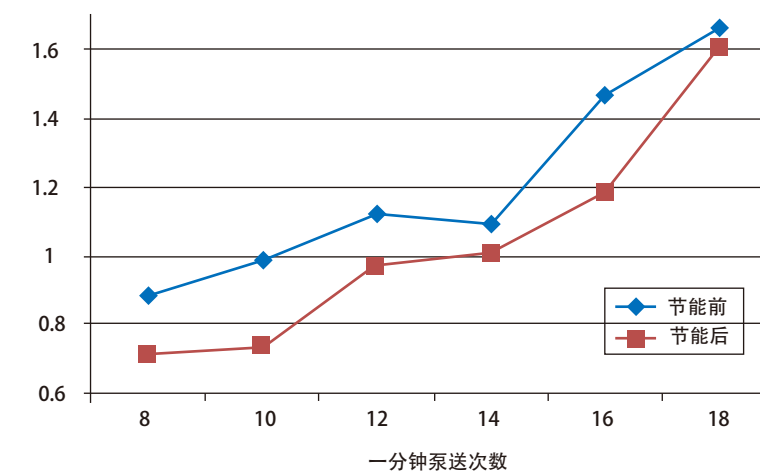

更完美的细节设计

PERFECT DETAIL DESIGN

更实用的配置选择 **More practical configuration option**

更便捷的维修保养 **Easier repair and maintenance**

更安全的设计理念 **Safer design concept**

更专业的技术细节 **More professional technical details**

更舒适的使用体验 **More comfortable use experience**



选配空压机
OPTIONAL AIR COMPRESSOR



遥控电缆收放
REMOTE CONTROL OF
CABLE ROLLING AND UNROLLING



外置式输送管
EXTERNAL DELIVERY PIPE



多级过滤系统
MULTILEVEL FILTER SYSTEM



快开式防护栏
QUICK-OPEN GUARDRAIL

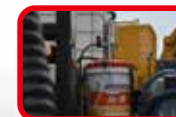

自动润滑系统
AUTOMATIC LUBRICATION SYSTEM

耐磨环自动补偿
AUTOMATIC COMPENSATION OF WEAR RING

液压系统防吸空保护
HYDRAULIC SYSTEM'S AIR SUCTION PROTECTION

液压油自动冷却技术
AUTOMATIC COOLING TECHNOLOGY OF HYDRAULIC OIL

自动集中稀油润滑
AUTOMATIC CENTRALIZED THIN OIL LUBRICATION

自动反搅功能保护
AUTOMATIC REVERSE AGITATING PROTECTION

主泵过载保护
PUMP OVERLOAD PROTECTION

全程过滤技术
FULL-LOOP FILTER TECHNOLOGY

活塞自动退回技术
PISTON'S AUTOMATIC RETURN TECHNOLOGY

易拆装链式卡环
CHAIN-TYPE SNAP RING EASY
FOR ASSEMBLY AND DISASSEMBLY



HPS30V CONCRETE SPRAYING TROLLEY

HP530V混凝土喷射台车

- HPS30V混凝土喷射台车是集行走、泵送、喷射于一体的混凝土设备，具有性能稳定、操作简单、回弹率低、施工质量高的特点；配备静液压传动刚性底盘，四轮驱动、四轮转向，动力性能优良、爬坡性能好，尤其适合路面崎岖的场地。
- HPS30V concrete spraying trolley is an equipment integrating traveling, pumping and spraying, featuring stable performance, easy operation, low rebound ratio and high-quality construction. It is provided with rigid chassis with hydrostatic transmission, four-wheel drive and four-wheel steering, featuring excellent dynamic performance and good gradeability, especially suitable for work sites with rugged roads.



静液压驱动底盘 HYDROSTATICALLY DRIVEN CHASSIS

- 整车四轮驱动、四轮转向，适用路面崎岖等恶劣工况。配备国际知名品牌行走系统，具有控制精确、动特性优良及可靠性高等特点。
- The machine adopts four-wheel drive and four-wheel steering, suitable for harsh work conditions in rugged areas. And it is equipped with a travelling system of world-famous brands, featuring precise control, dynamic response and high reliability,

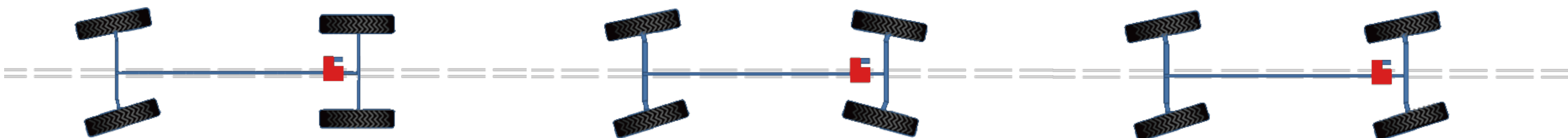

参数表

Parameter table



HPC30V、HPS30V



类别 CATEGORY	项目 ITEM	单位 UNIT	HPC30V	HPS30V
行驶系统 Traveling system	外形尺寸 Outline dimension	mm	9360×2500×3660	8720×2595×3190
	整机重量 Overall weight	kg	18000	16550
	发动机额定功率 Rated power of engine	kW/rpm	132 /2400	82 /2300
	废气排放标准 Emission standard	—	国 V China V	国 III China III
	爬坡能力 Gradeability	%	30	34.4
	转弯半径 Turning radius	m	9.5	5.9
	最高时速 Max. speed/hour	km/h	90	25
喷射系统 Spraying system	最大喷射高度 Max. spraying height	m	18	17
	最大喷射宽度 Max. spraying width	m	29.6	30
	前方最远喷射距离 Max. front spraying distance	m	14.8	15
	最小可喷射作业隧道高度 Min. permissible tunnel height for spraying operation	m	4	4
	最大作业深度 Max. reach depth	m	7	8
	喷嘴座轴向回转 Axial rotation of nozzle seat	°	360	360
	喷嘴座轴向摆动 Axial swing of nozzle seat	°	240	240
喷嘴偏转角X刷动 Nozzle deflection angle X Turning angle of brush	°	8×360	8×360	
泵送系统 Pumping system	最大理论喷射量 Max. theoretical spraying capacity	m³/h	30	30
	最大泵送压力 Max. pumping pressure	MPa	8	8
	混凝土缸径/行程 Concrete cylinder diameter/stroke	mm	180/1000	180/1000
	料斗容积 Hopper capacity	L	500	500
	允许骨料最大粒径 (泵送/喷射) Max. permissible aggregate diameter (pumping/spraying)	mm	22/16	22/16
	配料型式 Transfer tube	—	裙阀 Rock valve	裙阀 Rock valve
高压风 Air compressor	空压机 Air compressor		选配	标配
	供风量 Wind supply capacity	m³/min	10~13	13.3
	风压 Wind pressure	MPa	0.8	0.8
速凝剂 Accelerant	输送压力 Delivery pressure	MPa	0.8	0.8
	速凝剂计量/输送能力 Accelerant weighing/delivery capacity	L/h	60~600	60~600



HPC30V混凝土喷浆车
张家口崇礼铁路太子城隧道
HPC30V truck-mounted concrete spraying machine
Taizheng tunnel along Chongli railway in Zhangjiakou



HPC30V混凝土喷浆车
福建泉州佛仔格隧道
HPC30V truck-mounted concrete spraying machine
Fuozige tunnel in Quanzhou, Fujian



HPC30V混凝土喷浆车
福建三明兴泉铁路三阳隧道
HPC30V truck-mounted concrete spraying machine
Sanyang tunnel along Xingquan railway in Sanming, Fujian



HPC30V混凝土喷浆车
贵州荔榕高速姑两隧道
HPC30V truck-mounted concrete spraying machine
Guliang tunnel along Lirong expressway in Guizhou



HPC30V混凝土喷浆车
济南绕城高速二环舜玉路地下隧道
HPC30V truck-mounted concrete spraying machine
Shunyulu underground tunnel along Second Ring Road of Jinan Ring Expressway



HPC30V混凝土喷浆车
四川达州雷音铺隧道
HPC30V truck-mounted concrete spraying machine
Leiyinpu tunnel in Dazhou, Sichuan



HPC30V混凝土喷浆车 河南洛阳故县隧道
HPC30V truck-mounted concrete spraying machine
Guxian tunnel in Luoyang, Henan



HPC30V混凝土喷浆车 陕西韩城集义隧道
HPC30V truck-mounted concrete spraying machine
Jiyi tunnel in Hancheng, Shaanxi



HPC30V混凝土喷浆车 浙江台州合溪里隧道
HPC30V truck-mounted concrete spraying machine
Hexili tunnel in Taizhou, Zhejiang



HPS30V混凝土喷射台车 云南大临铁路新民隧道
HPS30V concrete spraying trolley
Xinmin tunnel along Dalin railway in Yunnan